

Constant Current Regulator Type MCR400



Application

The constant current regulator MCR400 is the latest in a line of regulators specifically intended for the supply of series circuits for use on airfield lighting circuits.

General Details

With the standard high speed built in serial data communications, the Constant Current Regulator (CCR) is able to communicate with most PC or PLC control systems.

To comply with statutory regulations, the CCR cabinet housing is divided into three areas, electronic control, low voltage area and main high voltage area. The electronic control area is situated behind a hinged panel at the front of the cabinet with no access to the other areas.

The constant current regulator MCR400 is supplied as a free standing unit, with or without castors. Requiring minimum floor space, it is available in ratings from 1.5kW to 30kW.

An alternative shelf mounting version MCR200 is also available in ratings from 1.5kW to 7.5kW. This version is also stackable.

Built within a proven robust welded steel cabinet the CCR is self-contained with all facilities and can include up to 5 circuit selectors integral to the floor mounting cabinet.

The smaller shelf mounting unit is prewired for connection to an external circuit selector unit.

For ease of maintenance, all modules within the CCR are easily accessible for servicing or replacement without the use of special tools.

Standard 6.6 Amp and 12 Amp series current versions available for all ratings.

All units use natural air convection cooling, no fans.

Standard Features

- Microprocessor control with comprehensive status monitoring.
- Continuous software integrity checking for added reliability.
- Simple set up using menu and units front panel push buttons
- Matching taps on output transformer for improved primary power factor and efficiency.
- 3, 5 or 7 selectable brightness steps.
- Remote control selectable between conventional 24/48V DC Multi-wire or RS485 serial link communications using Modbus/Jbus as standard.
- All monitored functions available via the serial link and via volt free relay contacts for use in a multi-wire installation as standard

Constant Current Regulator Type MCR400

Large LCD display for simultaneous display of all local status information: -

- Series current displayed with inband brightness percentage
- Brightness step selected (local & remote)
- Brightness out of band
- Power fail
- Over current trip
- Open circuit trip
- Lamp failure 2 stage (if option fitted)
- VA drop error (if option fitted)
- 2 stage earth leakage detector with adjustable alarm levels (if option fitted)
- Hours run counter as standard
- Volt free n/o relay contact
- Current flowing remote indication
- Power on remote indication
- Local/standby selected remote indication
- Over current remote indication
- Open circuit remote indication
- Earth leakage stage 1 & 2 remote indication (option)
- Failed lamp detector stage 1 & 2 remote indication (option)
- VA drop remote indication (option)
- Brightness out of band

Options

- Failed lamp detector (2 stage)
- Earth Leakage detector (2 stage)
- Brightness in-band relays

- Lightning arrestors
- 100% current flow elapsed time counter
- VA drop detector
- 48V DC internal power supply for remote control
- Circuit selectors (2 alternate or 2- 5 simultaneous)
- Primary circuit current monitoring (4-20mA output)
- Castors
- Vermin proofing
- MCR405 designed to comply with PSA (RAF) requirements

Controls & Indicators

The constant current regulators controls and indicators have been kept to a minimum so that setting up is quick and simple. All parameters and functions are preloaded in software which can be adjusted, enabled or disabled by using the front panel push buttons. Brightness settings can also be adjusted manually from the push buttons on the units front panel.

- Main Input Isolator
- Power on indicator
- 3 way rotary switch (local - standby - remote)
- Adjust current push buttons
- Local brightness stage 1 – 7 (selected by + & - pushbuttons)
- LCD display
- Hours run counter
- Local circuit select push buttons (option)
- Circuit select LED Indicators (option)

Constant Current Regulator Type MCR400

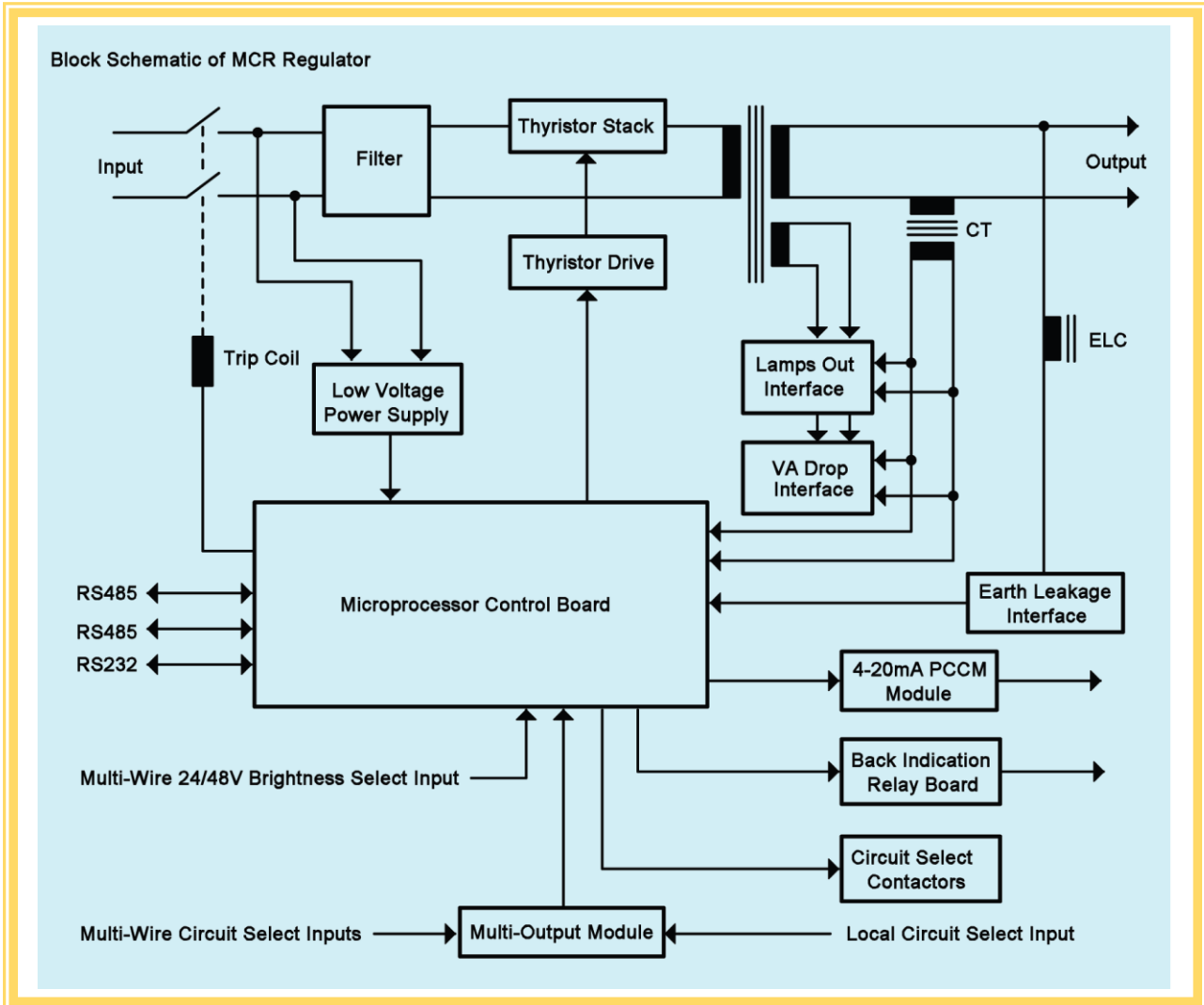

Typical Primary Power and Efficiency

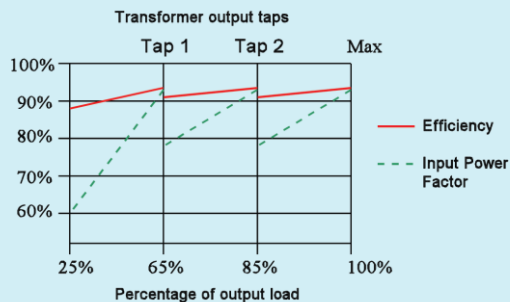

Alternative taps can be supplied on request

Compatible with Standards

ICAO – Aerodrome Design Manual, Part 5, Para 3.2.1.4 to 3.2.1.6
 CAP168 – Chapter 6, Para 12.5.1.
 FAA – AC 150/5345-10E
 BS IEC 61822
 BS EN 61000-6-4 2001 Emissions
 BS EN 61000-6-2 2001 Immunity

Constant Current Regulator Type MCR400

Brief Specifications

Type:	Solid State Thyristor Control
Ratings available:	1.5, 2.7, 4, 5, 7.5, 10, 12.5, 15, 20, 25, 30kW
Input Voltage:	Single Phase 200-250V 50/60Hz (1.5-20kW) Single Phase 380-450V 50/60Hz (1.5-30kW)
Power Factor & Efficiency	Better than 90% at nominal input voltage with resistive matched load
Output Current:	6.6 Amp or 12 Amp
Output Current Accuracy:	±1% of setting for supply variations +6% and -10% and loads from 0-100%
Response Time:	Less than 300mS (soft start on all settings)
Over Current Protection:	Automatic phase back and retry at 103% (selectable) De-energize at 105%
Open Circuit Protection:	De-energize within 100mS
Remote Control:	Selectable 24/48V DC multi-wire and RS485 serial link communications
Communications:	2 Channels RS485 multi-drop using Modbus/Jbus protocol and RS232 port for use with laptop computer
Ventilation:	Natural air cooled
Temperature Range:	-20°C to +55°C (operating)
Humidity:	Max 95% Non-condensing
Altitude:	Zero to 2000m above sea level
Cabinet:	All steel construction to IP21 (IP41 available on request)

Dimensions and Weights

Rating	1 Output	2 Output	3 Output	4 Output	5 Output
1.5kW	170kg	180kg	182kg	184kg	186kg
2.7kW	180kg	190kg	192kg	194kg	196kg
4kW	185kg	195kg	197kg	199kg	201kg
5kW	190kg	200kg	202kg	204kg	206kg
7.5kW	210kg	220kg	222kg	224kg	226kg
10kW	220kg	230kg	232kg	234kg	236kg
12.5kW	240kg	250kg	252kg	254kg	256kg
15kW	300kg	310kg	312kg	314kg	316kg
20kW	320kg	330kg	332kg	334kg	336kg
25kW	360kg	370kg	372kg	374kg	376kg
30kW	370kg	380kg	382kg	384kg	386kg

All ratings housed in standard size cabinet	
Cabinet size: -	
Height =	1250mm
Width =	575mm
Depth =	645mm
Shipping Volume =	0.71m ³
.	
Lifting lugs supplied as standard. Add 60mm to height.	
Castors supplied as option. Add 130mm to height.	