



advancement group UK



# LED PAPI

## Precision Approach Path Indicator

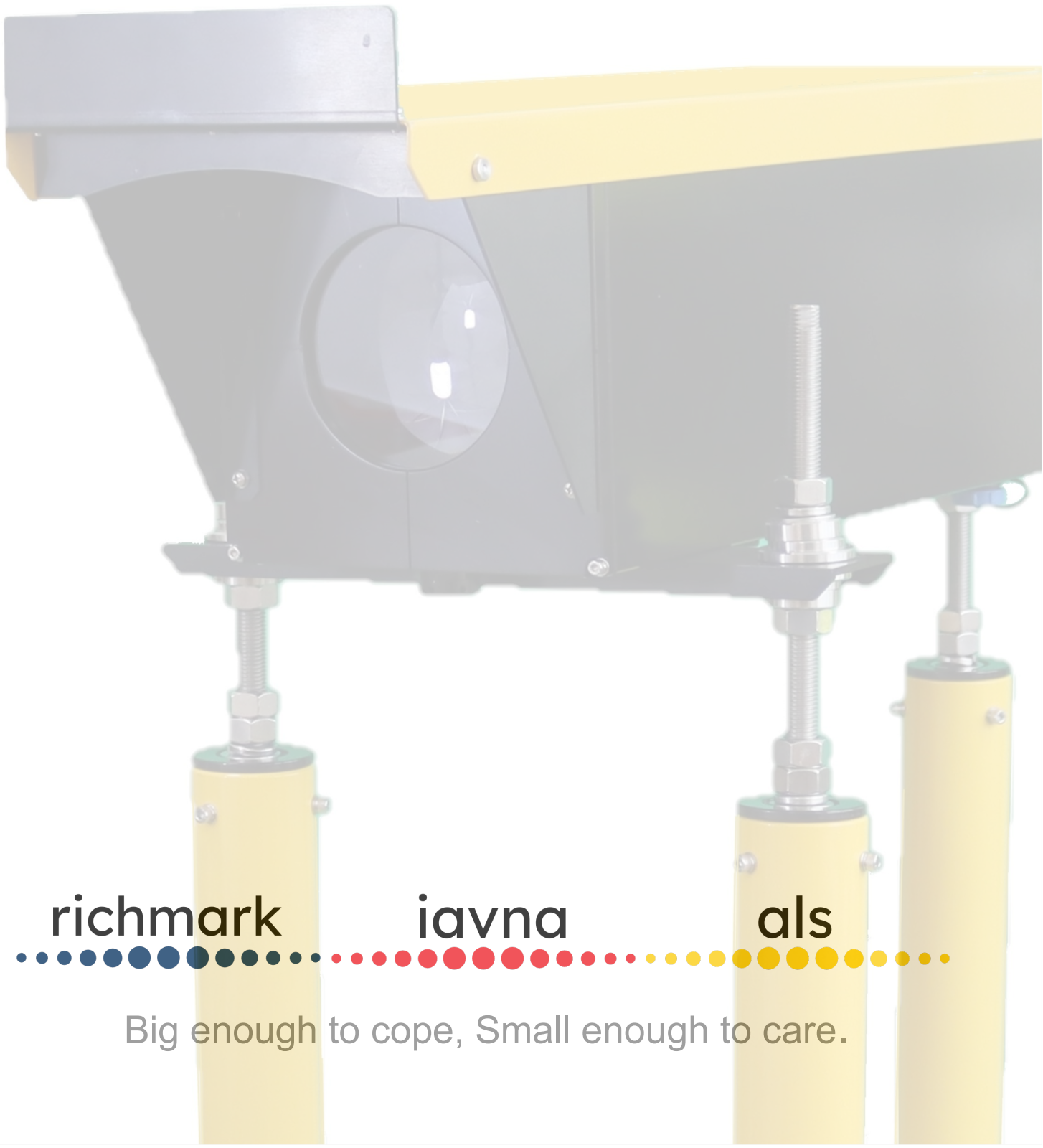

richmark

iavna

als



Big enough to cope, Small enough to care.

# als



## LED PAPI

Our LED PAPI is a new flagship product. Its unique design makes for easy installation and maintenance. With a power consumption of 57W this PAPI is significantly more economical than similar products.

It is both quick and easy to install and set up and comes with an IP65 rating.

The body construction is built to last and is manufactured from 5mm thick aluminium to provide superior thermal management. It also has a wide operating range of  $-55^{\circ}\text{C}$  to  $+55^{\circ}\text{C}$  and is suitable for global projects.

The ALS DTS PAPI Lights are part of our popular range of Airfield Ground Lighting.

They allow the pilot to establish and maintain an exact glide path to the runway for the final landing approach phase, right to the touchdown point both day and night.

This enables the approach procedure to be performed with the utmost accuracy and safety.

The system consists of four light units equally spaced at the side of the runway adjacent to the origin of the glide path. The nominal glide slope angle is midway between the central pair of the four units. The PAPI emits two high powered beams of light, the lower part is red and the top part white.



## Features

- Aluminium alloy body an high quality powder coating to give an excellent weather resistance (IP65).
- Stable three point supporting structure and accurate adjustment of elevation angle.
- Easy to assemble. Hinged lid allows for hands free maintenance.
- Key components thermally potted for longer life.
- Precise positioning of optical components and clear transition from white to red.
- High quality LED chips for consistent performance.
- Optimised thermal design (5mm thick body) to lower operating temperature of the driver and prolong life.
- Waterproof breathable valve prevents internal condensation.
- Lamp fault alarm and tilt switch allow for troubleshooting.
- Handy mounting position for clinometer for alignment checks.
- Can be connected with antenna for remote monitoring.

## Environmental

- Operating Temperature: -55~55°C
- Protection Class: IP65
- Humidity: 0~100%

## Electrical

- Connection: 1×FAA L-823
- Rated Input Current: 6.6A
- Power Consumption: 57W
- Emission: IEC 61000-6-4
- Immunity: IEC 61000-6-2
- Service Life/Lamp Life: >50000h

## Weight

- Net Weight: 24Kg



## Technical Data

### Environmental

Operating Temperature:  $-55^{\circ}\text{C} \sim +55^{\circ}\text{C}$

Ingress Protection: IP65

Humidity: 0~100%

### Electrical

Connection: 1 x FAA L-823

Rated Input Current: 6.6A

Power Consumption: 57W

Emission: IEC 61000-6-4

Immunity: IEC 61000-6-2

Service Life: >50,000 hours

### Compliance

FAA - AC-137-CA-2015-03-R1

ICAO - Annex 14 Vol 1

EASA - CS-ADR-DSN

CAAC - EB No 67

IEC - TS 61827

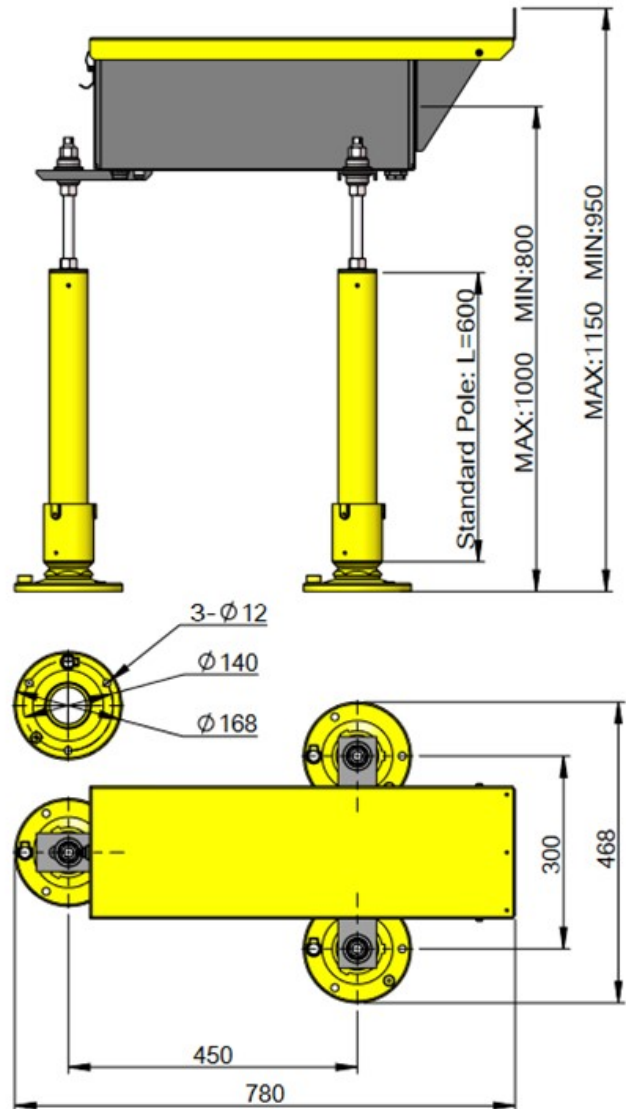

## Photometric Performance Candelas

| Aera | AVG(White) | AVG(Red) | AVG(White)/AVG(Red) | Min(red) | Min(Red-Standard) |
|------|------------|----------|---------------------|----------|-------------------|
|      | 50917      | 23649    | 2.15                | 20149    | 15000             |
|      | 41859      | 20295    | 2.06                | 18232    | 10000             |
|      | 39735      | 18486    | 2.15                | 15414    | 7000              |
|      | 32665      | 14381    | 2.27                | 4942     | 4000              |



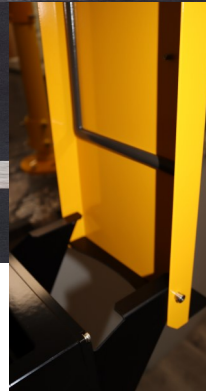

## Benefits

Potted Electrical Compo-

High Quality Gasketing

Precision Lens

PAPI's are a fundamental part of airfield ground lighting and often the first visual alert for the pilot when commencing the glide path descent.

The Halogen models have been used for many years and need regular maintenance and lamp changes, every hour a lamp burns it get a little less bright.

By utilising the latest LED technology this vital piece of equipment can keep the airfield open longer, and provide feedback via controls if required.

They consistently give the right light output from high quality LED's with excellent precision, proving a clear transition from Red to White for improved accuracy.





[www.richmark.co.uk](http://www.richmark.co.uk)

[www.iavna.net](http://www.iavna.net)

[www.airfieldlightingsystems.co.uk](http://www.airfieldlightingsystems.co.uk)

Follow us for up to date information or sign up to our  
newsletter at [www.iavna.net](http://www.iavna.net)



**richmark**

**iavna**

**als**



AGL Advancement Group

Aviation House, Russell Gardens, Wickford, Essex SS11 8BF

+44 1702 547866 [sales@iavna.net](mailto:sales@iavna.net)

[www.iavna.net](http://www.iavna.net)