

DTS – 8 Inch LED Inset Lights Runway

AIRFIELD GROUND LIGHTING SOLUTIONS



8" LED Inset Lights

- RC/IN Runway Centre Line • TZ/IN Touchdown Zone • FI/IN Rapid Exit Taxiway Indicator
- RE/IN Runway End • RE/IN Stopway • THL/IN Take-off and Hold

DTS – 8 Inch LED Inset Lights Runway



FEATURES

- Low protrusion of 6.3mm above ground level
- Modulized electrical driver and LED assembly for simplicity of maintenance
- Efficient and stable optical output, suitable for operation with 6.6A and 2.2A CCRs
- Unique optical design, ensuring luminous efficacy and color consistency
- Strict thermal management solution increasing life expectancy
- Highly conductive aluminium mechanical components with special treatment, suitable for various weather conditions
- Built-in surge protection
- Optional Fail Open System



DTS – 8 Inch LED Inset Lights Runway

TECHNICAL DATA



MECHANICAL

- Diameter 203mm
- Flange Thickness 19mm
- Protrusion Above Ground $\leq 6.3\text{mm}$
- Depth Below Flange 67mm
- Mounting 2 x M10 bolts
- Static Load Resistance $\geq 20\text{t}$
- Dynamic Load Resistance 40J



ENVIRONMENTAL

- Operating Temperature $-55^{\circ}\text{C}\sim+55^{\circ}\text{C}$
- Storage Temperature $-55^{\circ}\text{C}\sim+85^{\circ}\text{C}$
- Protection Class IP68
- Humidity 0~100%



ELECTRICAL

- Connection FAA L-823
- Rated Input Current 6.6A/2.2A
- Power Factor > 0.9

Power Consumption

Runway Centre Line-White	20VA	Rapid Exit Taxiway Indicator	20.5VA
Runway Centre Line-Red	16.5VA	Runway End	18.5VA
Runway Centre Line -White/White	26.5VA	Stopway	18.5VA
Runway Centre Line -White/Red	22.5VA	Take-off and Hold	18.5VA
Touchdown Zone	20.5VA		

- Fail Open Reaction on output open circuit and output short circuit
- Emission IEC 61000-6-4
- Immunity IEC 61000-6-2
- Service Life LED useful lamp life $> 80000\text{h}$



DTS – 8 Inch LED Inset Lights Runway

DIMENSIONS

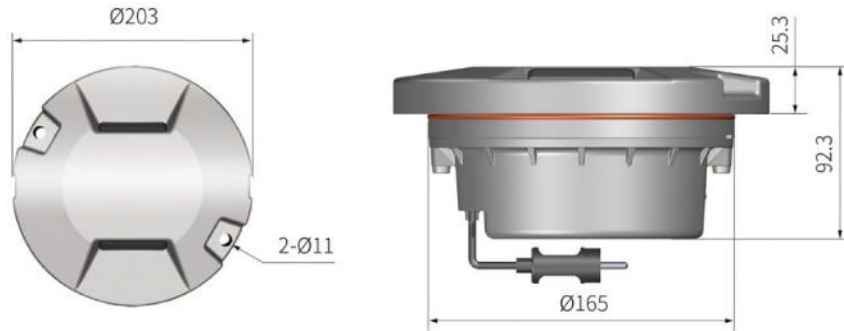

COMPONENTS

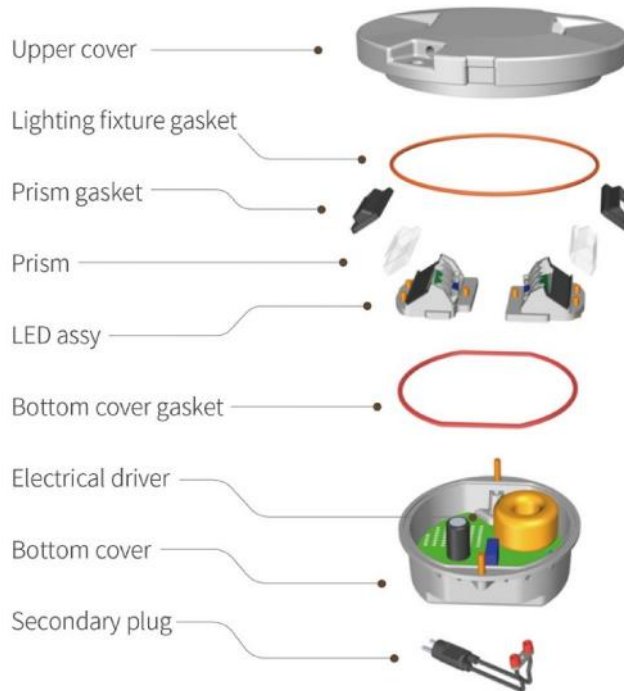
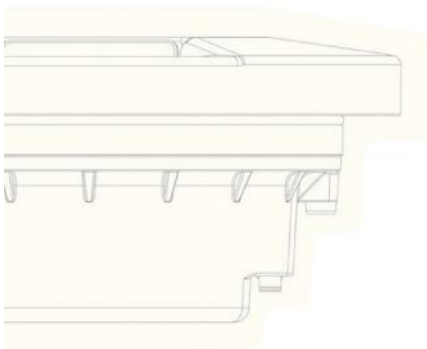

ACCESSORIES

- 8 inches shallow base assy (bottom entry/side entry)
- 12 inches shallow base assy (bottom entry/side entry)
- 12 inches deep base assy
- 12-8 adapter ring assy
- L-823 receptacle
- 8 inches light fixture handle

PACKAGING



Dimensions: 253mm (L) x 223mm (W) x 107mm (H)

Net Weight: 3.5kg Gross Weight: 3.7kg

* Packaging is subject to upgradation. Above data are reference values.

DTS – 8 Inch LED Inset Lights Runway

CHROMATICITY

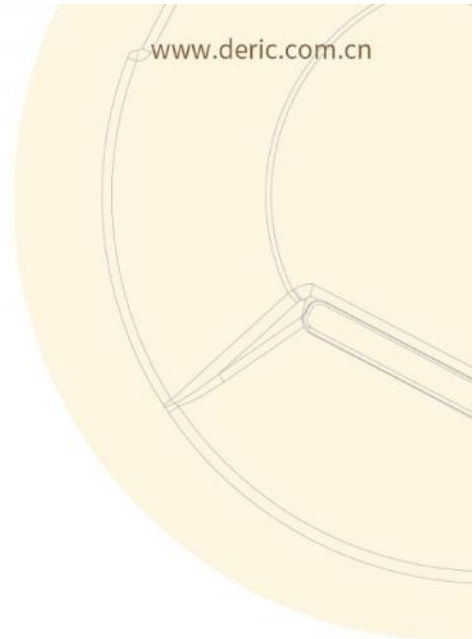
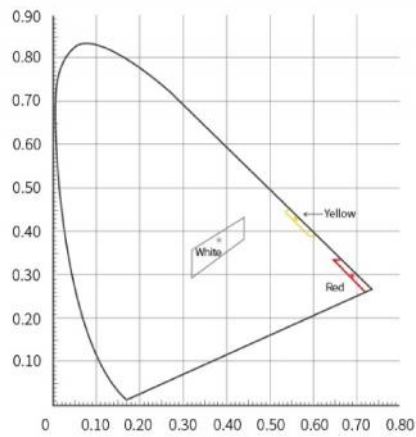

PHOTOMETRICS

┌ Runway Center Line ┐



┌ Runway Center Line ┐

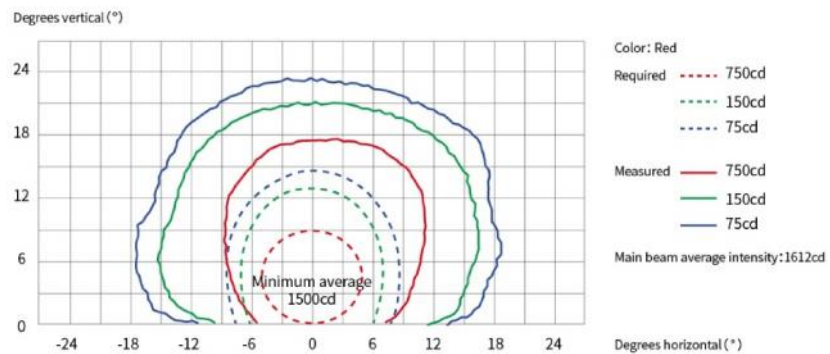

DTS – 8 Inch LED Inset Lights Runway

ORDERING CODES

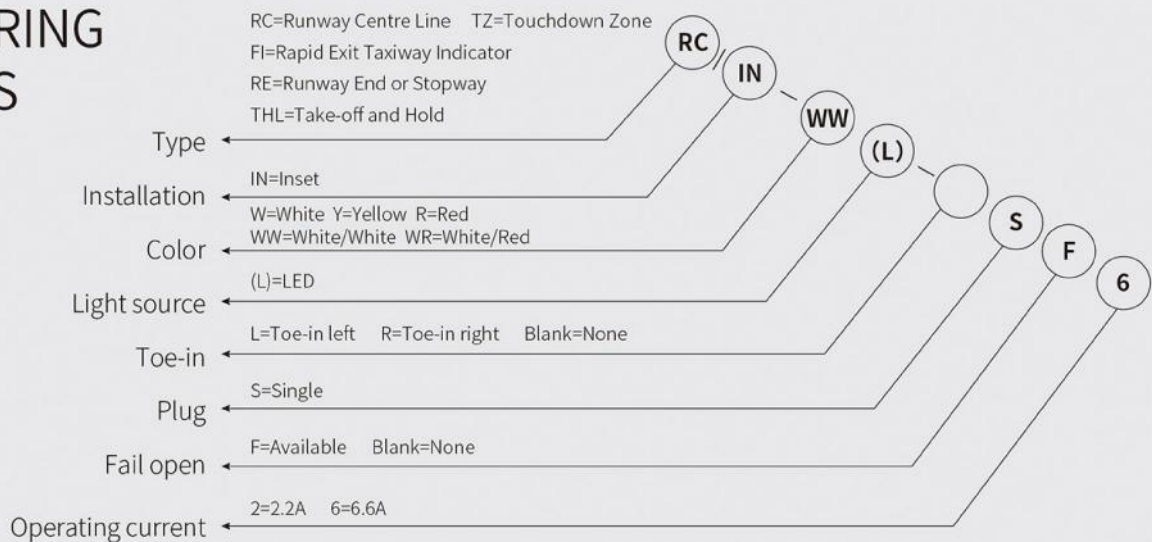

★ Accessories should be ordered separately